

# Inverse Isolation Amplifier DB 6250

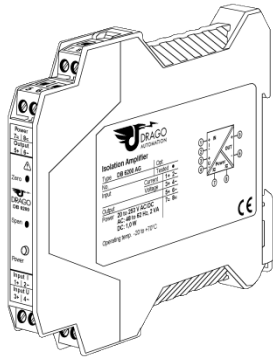

Read these instructions before using the product and retain for future information.

## DB 6250

### 2. Short description

The 3-way inverse isolation amplifier is used for electrical isolation and inverse conversion of unipolar process signals. Input and output range can be set by using DIP switch. The Zero/Span Adjustment on the front allows a fine-tuning of the measurement signal and the recalibration after a range selection.

The 3-way isolation guarantees reliable decoupling of the sensor circuit from the processing circuit and prevents linked measurement circuits from influencing each other. The Protective Separation with high isolation level provides protection for personnel and downstream devices against impermissibly high voltage.

### 3. Functioning

The input signal is modulated and then electrically decoupled using a transformer. The isolated signal is then made available at the output, demodulated, filtered and amplified.

### 4. Configuration

#### 4.1 Equipment

A screwdriver with a width of 2.5 mm is required to open and adjust the unit and to connect the wires to the screw clamp terminals.

#### 4.1 Opening The Unit

Using a screwdriver, release the snap fittings of the upper part of the housing on both sides (1). The upper part of the housing and the electronics can now be pulled out by approximately 3 cm (2).

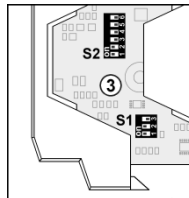
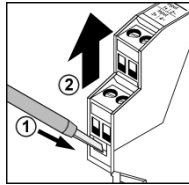

#### 4.3 Settings

Set the input and output ranges with DIP switch (3) as indicated in the following table:

Input S1-	Range			Output S2-					
	1	2	3	1	2	3	4	5	6
			•	0 ... 10 V				•	•
			•	2 ... 10 V				•	•
		•		0 ... 5 V				•	•
		•	•	1 ... 5 V				•	•
			•	0 ... 20 mA				•	•
		•		4 ... 20 mA				•	•
		•	•	0 ... 10 mA				•	•
		•	•	2 ... 10 mA				•	•
				Bandwidth 8 kHz					
				Bandwidth 100 Hz					

• = on

After each range selection a Zero/Span Adjustment ought to be executed!

### 5. Mounting, Electrical Connection

The isolation transmitter is mounted on standard 35 mm DIN rail.

Terminal assignments			
1	Input + I	5	Output +
2	Input - I	6	Output -
3	Input + U	7	Power supply ≙
4	Input - U	8	Power supply ≙

#### Warning!

Do not operate inputs for current and voltage simultaneously!

### 6. Technical Data

Input	Voltage	Current
Input signal	0 - 10 V 0 - 5 V	0 - 20 mA 0 - 10 mA
(terminal/switch selectable)	2 - 10 V 1 - 5 V	4 - 20 mA 2 - 10 mA
Input resistance	Approx. 1 MΩ	Approx. 22 Ω
Input capacitance	Approx. 1 nF	Approx. 1 nF
Overload	Voltage limitation via 30 V Z-Diode, max. continuous current 30 mA	≤ 200 mA
Output	Voltage	Current
Output signal	0 - 10 V 0 - 5 V	0 - 20 mA 0 - 10 mA
(switch selectable)	2 - 10 V 1 - 5 V	4 - 20 mA 2 - 10 mA
Load	≤ 10 mA (1 kΩ at 10 V)	≤ 12 V (600 Ω at 20 mA)
Linear transmission range	-2 to + 110%, inverse characteristic	
Ripple	< 20 mV <sub>rms</sub>	
General data		
Transmission error	< 0.1 % full scale	
Temperature coefficient <sup>1)</sup>	< 100 ppm/K of end value	
Zero/Span adjustment	± 10 % of end value	
Cut-off frequency (-3 dB)	> 10 kHz switchable to approx. 30 Hz	
Test voltage	4 kV, 50 Hz	
Working voltage <sup>2)</sup> (Basic insulation)	1000 V AC/DC for overvoltage category II and contamination class 2 acc. to EN 61010 part 1	
Protection against dangerous body currents <sup>2)</sup>	Protective Separation by reinforced insulation acc. to EN 61010 part 1 up to 600 V AC/DC for overvoltage category II and contamination class 2 between input and output and power supply.	
Ambient temperature	Operation - 20 °C to + 70 °C (-4 to 158 °F) Transport - 35 °C to + 85 °C (-31 to 185 °F) and storage	
Power supply	20 to 253 V AC/DC AC 48 ... 62 Hz, approx. 2 VA DC approx. 1,0 W	
EMC <sup>3)</sup>	EN 61326-1	
Construction	12,5 mm (0.5") housing, protection type: IP 20	
Connection	pluggable screw connection solid/stranded 0.2 to 2.5 mm <sup>2</sup> , AWG 24 to 12 tightening torque 0.5 to 0.6 Nm	
Weight	Approx. 100 g	

- Average TC in specified operating temperature range
- As far as relevant the standards and rules mentioned above are considered by development and production of our devices. In addition relevant assembly rules are to be considered by installation of our devices in other equipment. For applications with high working voltages, take measures to prevent accidental contact and make sure that there is sufficient distance or insulation between adjacent situated devices.
- Minor deviations possible during interference

### 7. Block Diagram

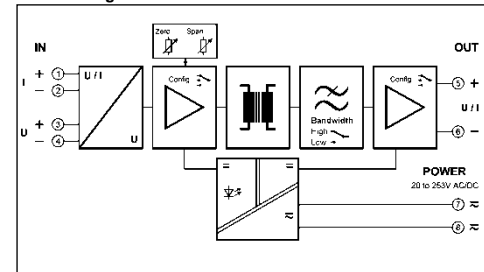

### 8. Order Information

Product	Input / Output	Part No.
Inverse Isolation Amplifier	configurable	DB 6250 AG

### 9. Dimensions

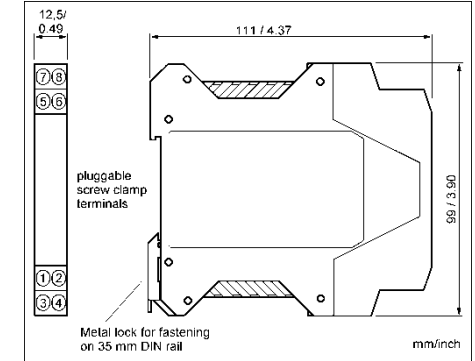

### LIMITED WARRANTY

DRAGO Automation GmbH hereby warrants that the Product will be free from defects in materials or workmanship for a period of **five (5) years** from the date of delivery ("Limited Warranty"). This Limited Warranty is limited to repair or replacement at DRAGO's option and is effective only for the first end-user of the Product. This Limited Warranty applies only if the Product:

- is installed according to the instructions furnished by DRAGO;
- is connected to a proper power supply;
- is not misused or abused; and
- there is no evidence of tampering, mishandling, neglect, accidental damage, modification or repair without the approval of DRAGO or damage done to the Product by anyone other than DRAGO.

Delivery conditions are based upon the „GENERAL CONDITIONS FOR THE SUPPLY OF PRODUCTS AND SERVICES OF THE ELECTRICAL AND ELECTRONICS INDUSTRY“ recommended by the Zentralverband Elektrotechnik- und Elektronikindustrie (ZVEI) e.V.

Subject to change!

### DRAGO Automation GmbH

Waldstrasse 86 - 90  
13403 BERLIN  
GERMANY

Phone: +49 (0)30 40 99 82 - 0  
Fax: +49 (0)30 40 99 82 - 10

E-Mail: info@drago-automation.de  
Internet: www.drago-automation.de

### 1. Before Startup



When operating the isolating amplifier, certain parts of the module can carry dangerous voltage! Ignoring the warnings can lead to serious injury and/or cause damage!

The isolating amplifier should only be installed and put into operation by qualified staff. The staff must have studied the warnings in these operating instructions thoroughly.

The isolating amplifier may not be put into operation if the housing is open. The adjustment with the potentiometer on the front may only be carried out with a screwdriver which is securely insulated against the input voltage!

In applications with high operating voltages sufficient distance and isolation as well as shock protection must be ensured.

Safe and trouble-free operation of this device can only be guaranteed if transport, storage and installation are carried out correctly and operation and maintenance are carried out with care.



Appropriate safety measures against electrostatic discharge (ESD) should be taken during range selection and assembly on the transmitter.